



2N[®] Helios IP Solo

IP Intercom



Installation Manual

Firmware:

Version: 2.9

The 2N TELEKOMUNIKACE a.s. is a Czech manufacturer and supplier of telecommunications equipment.



The product family developed by 2N TELEKOMUNIKACE a.s. includes GSM gateways, private branch exchanges (PBX), and door and lift communicators. 2N TELEKOMUNIKACE a.s. has been ranked among the Czech top companies for years and represented a symbol of stability and prosperity on the telecommunications market for almost two decades. At present, we export our products into over 120 countries worldwide and have exclusive distributors on all continents.



2N[®] is a registered trademark of 2N TELEKOMUNIKACE a.s. Any product and/or other names mentioned herein are registered trademarks and/or trademarks or brands protected by law.



2N TELEKOMUNIKACE a.s. administers the FAQ database to help you quickly find information and to answer your questions about 2N products and services. On www.faq.2n.cz you can find information regarding products adjustment and instructions for optimum use and procedures „What to do if...“.



2N TELEKOMUNIKACE a.s. hereby declares that the 2N[®] product complies with all basic requirements and other relevant provisions of the 1999/5/EC directive. For the full wording of the Declaration of Conformity see the CD-ROM (if enclosed) or our website at www.2n.cz.



This device complies with part 15 of the FCC Rules. Operation is subject to the following two conditions: (1) This device may not cause harmful interference, and (2) this device must accept any interference received, including interference that may cause undesired operation.



The 2N TELEKOMUNIKACE a.s. is the holder of the ISO 9001:2009 certificate. All development, production and distribution processes of the company are managed by this standard and guarantee a high quality, technical level and professional aspect of all our products.

Content:

- 1. Product Overview
 - 1.1 Components and Associated Products
 - 1.2 Terms and Symbols
- 2. Description and Installation
 - 2.1 Before You Start
 - 2.2 Mechanical Installation
 - Main Unit Mounting
 - 2.3 Electric Installation
 - 2.4 Extending Module Connection
 - 2.5 Completion
- 3. Function and Use
 - 3.1 Configuration
 - 3.2 Intercom Control as Viewed by External User
 - 3.3 Intercom Control as Viewed by Internal User
 - 3.4 Maintenance
 - 3.5 Downloads
- 4. Technical Parameters
- 5. Supplementary Information
 - 5.1 Troubleshooting
 - 5.2 Directives, Laws and Regulations
 - 5.3 General Instructions and Cautions

1. Product Overview

Here is what you can find in this section:

- 1.1 Components and Associated Products
- 1.2 Terms and Symbols

Basic Features

2N[®] Helios IP Solo is an elegant and reliable intercom equipped with lots of useful functions. Thanks to SIP support and compatibility with major brands of PBX manufacturers, it can benefit from using VoIP networks. 2N[®] Helios IP Solo can be used as a door or special purpose intercom for office buildings, residential areas and other applications.

Wide angle HD camera - allows the tenant to see the calling person on his or her videophone or PC screen in high resolution. The camera itself is hidden behind a darkened glass, so it is not visible. The intercom is equipped with night vision, which automatically selects the night/day mode according to light.

Quick dial button - there is 1 quick dial buttons in total. For this button, up to three separate phone numbers plus substitute users can be defined, which ensures that the called user is reached whenever needed. The button is backlit with a clear mechanical response. The nametag surface is scratch resistant.

Electric lock control - as part of the access system, the electrical lock can be controlled by a code entered on the keypad or the called phone, with the RFID card, via a PC application, etc. When necessary, more electrical outputs can be added. Numerous parameters allow for a wide spectrum of applications.

Robustness - 2N[®] Helios IP Solo is designed as a vandal resistant intercom, which withstands mechanical or weather conditions with no need to purchase extra accessories.

Audio quality - using the automatic echo cancelling system, full duplex communication is available at any time.

The installation of 2N[®] Helios IP Solo is very easy, all you have to do is assemble the required parts and modules and attach the network cable. The modules are plug&play, so there is no need to configure them manually. The intercom can be supplied from a 12 V DC power source, or using a PoE switch.



Use your PC with any internet browser to configure 2N[®] Helios IP Solo or apply the 2N[®] Access Commander to configure extensive installations of multiple intercoms.

Advantages of Use

- Elegant design
- Weather resistant
- Various modes of installation (flush, surface, plasterboard)
- Sensitive microphone and loud speaker
- Both-way audio communication – acoustic echo cancellation
- Integrated colour HD camera with wide-angle lense and hidden night vision
- Integrated switches of electric locks with wide setting options
- Optional integrated RFID card reader module
- PoE or 12 V DC power supply
- Configuration using web interface or dedicated PC application
- VoIP standard SIP 2.0 support
- 1999 Phone Book positions
- 20 user time profiles
- Video codecs (H.263, H.263+, H.264, MPEG-4, MJPEG)
- Audio codecs (G.711, G.729, G.722, L16/16kHz)
- HTTP server for configuration
- SNTP client for time synchronisation
- RTSP server for audio and video streaming, ONVIF compatible
- SMTP client for email sending, Picture to Email feature
- TFTP/HTTP client for automated firmware and configuration upgrade and update

1.1 Components and Associated Products

Main Units

<p>Part No. 9155301CF</p> 	<ul style="list-style-type: none">• Main unit• Flush mount
<p>Part No. 9155301CS</p> 	<ul style="list-style-type: none">• Main unit• Surface mount

Mounting Accessories

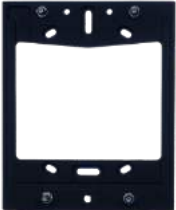
<p>Part No. 9155017</p> 	<ul style="list-style-type: none">• Flush mounting box• Designed for flush or plasterboard mounting.
<p>Part No. 9155068</p> 	<ul style="list-style-type: none">• Backplate• For not flat surface installation

Choose the proper frame and, if necessary, mounting box type depending on your particular 2N[®] Helios IP Solo installation needs. 2N[®] Helios IP Solo is designed for outdoor applications and requires no additional roof.

Internal Units

Part Numbers:

91378365

91378366



- 2N[®] Indoor Touch - black
- WiFi version (second part no.)
- The elegant internal touch panel, 2N[®] Indoor Touch, is suitable for all 2N Helios IP intercoms. On the panel's display not only can you find out who is at the door, but also start a conversation with the visitor, open the lock or turn on the light in the entrance hall.

Part Numbers:

91378365WH

91378366WH



- 2N[®] Indoor Touch - white
- WiFi version (second part no.)
- The elegant internal touch panel, 2N[®] Indoor Touch, is suitable for all 2N Helios IP intercoms. On the panel's display not only can you find out who is at the door, but also start a conversation with the visitor, open the lock or turn on the light in the entrance hall.

VoIP Phones

Part No. 91378357



- Grandstream GXV3240 VoIP video telephone
- GXV3240 is the successor to the popular GXV3140 model, which allows comfortable video calls in the IP network. Touchscreen and keyboard control.

Part No. 91378358



- Grandstream GXV3275 VoIP telephone
- GXV3275 is the successor to the popular GXV3175 model, which allows comfortable video calls in the IP network. Touchscreen control.

Electric Locks

Part No. 932071E



- BEFO 1121
- 12 V / 230 mA DC
- low consumption

Part No. 932081E





- BEFO 11221 with momentum pin
- 12 V / 230 mA DC
- low consumption
- For opening of the lock a short electrical impuls is sufficient, which unlocks the lock. Lock is then open until someone closes the door.

Part No. 932091E



- BEFO 11211MB with mechanical blocking
- 12 V / 230 mA DC
- low consumption
- Enables mechanically close or open the lock. When opened, the lock is open all the time. When closed, it behaves as standart electrical lock.



<p>Part No. 932061E</p> 	<ul style="list-style-type: none">• 211211 door signalling, low consumption• 12 V / 230 mA• A regular lock with a built-in contact to indicate whether the door is open or closed.
<p>Part No. 932072E</p> 	<ul style="list-style-type: none">• 31211 fail-safe• 12 V / 170 mA DC• The failsafe lock is closed when electricity is switched on. When electricity is interrupted, the lock is opened.

<p>Part No. 932062E</p> 	<ul style="list-style-type: none">• 321211 fail-safe, door signalling• 12 V / 170 mA• The failsafe lock is closed when electricity is switched on. When electricity is interrupted, the lock is opened.• It contains a built-in contact to indicate whether the door is open or closed.
---	--

✔ **Tip**

- [FAQ: Electric locks - Difference between locks in 2N Helios IP accessories](#)

Power Supply

<p>Part Numbers:</p> <p>91378100</p> <p>91378100E</p> <p>91378100US</p> 	<ul style="list-style-type: none"> • PoE injector - without cable • PoE injector - with EU cable • PoE injector - with US cable • For power supply of intercom via ethernet cable when PoE switch is not available.
<p>Part No. 91341481E</p> 	<ul style="list-style-type: none"> • Stabilised 12 V / 2 A power supply needs to be used when no PoE is available.
<p>Part No. 932928</p> 	<ul style="list-style-type: none"> • For external power supply of the lock with 12 V AC voltage.

Two-wire connection



Part No. 9159014EU/US/UK



- 2N[®] 2Wire
- (set of 2 adaptors and power source for EU/US/UK)
- The 2N[®] 2Wire converter allows you to use existing wiring (2 wires) from your original door bell or door intercom to connect any IP device. You don't have to configure anything, and you only need one 2N[®] 2Wire unit at each end of the cable and a power source connected to at least one of these units.

The 2N[®] 2Wire unit then provides **PoE** power not only to the second converter, but also to all other connected IP end devices.

External switches

<p>Part No. 9159010</p> 	<ul style="list-style-type: none">• 2N[®] Helios IP Security Relay• A handy add-on that significantly enhances door entry security as it prevents tampering with the intercom and forced opening of the lock. To be installed between intercom and lock, powered by the intercom.
<p>Part No. 9137410E</p> 	<ul style="list-style-type: none">• External IP Relay - 1 output• Standalone IP device which can be controlled by HTTP commands sent by Helios IP intercom, which can thus control devices on unlimited distance.
<p>Part No. 9137411E</p> 	<ul style="list-style-type: none">• External IP Relay - 4 outputs, PoE• Standalone IP device which can be controlled by HTTP commands sent by Helios IP intercom, which can thus control devices on unlimited distance.

Sensors and switches

Part No. 9159013



- Exit button
- A button for connection to a logic input for opening a door inside a building.

Part No. 9159012



- Magnetic door contact
- Set for installation on a door, enabling the status of door opening to be ascertained. Used when the intercom is used for door protection, to detect when the door is not

1.2 Terms and Symbols

The following symbols and pictograms are used in the manual:

 **Safety**

- Always abide by this information to prevent persons from injury.

 **Warning**

- Always abide by this information to prevent damage to the device.

 **Caution**

- Important information for system functionality.

 **Tip**

- Useful information for quick and efficient functionality.

 **Note**

- Routines or advice for efficient use of the device.

2. Description and Installation

Here is what you can find in this section:

- 2.1 Before You Start
- 2.2 Mechanical Installation
- 2.3 Electric Installation
- 2.4 Extending Module Connection
- 2.5 Completion

Product Completeness Check

Before you start please check whether the contents of the package of your new 2N[®] Helios IP Solo complies with the following list.

- 1x 2N[®] Helios IP Solo

Surface installation

- Installation manual
- 1x frame for surface installation
- frame holder set
- 3x dowels
- 3x screws
- 1x hex key
- 1x drill pattern
- 1x transparent name plate foil

Flush installation

- Installation manual
- 1x frame for flush installation
- frame holder set
- 4x screws
- 1x hex key
- 1x drill pattern
- 1x transparent name plate foil

2.2 Mechanical Installation

Mounting Types Overview

Refer to the table below for a list of mounting types and necessary components. You can assemble multiple units in all mounting types.

Flush mounting - classic bricks

- incl. hollow bricks, thermally insulated walls, etc.

What you need for mounting:

- a properly cut hole as instructed in the box package
- plaster, mounting glue, mounting foam or mortar as necessary
- 2N[®] Helios IP Solo, flush mounting boxes (Part No. 9155017)

Flush mounting - plasterboard

What you need for mounting:

- a properly cut hole as instructed in the box package
- 2N[®] Helios IP Solo, flush mounting boxes (Part No. 9155017)



Surface mounting

- concrete and steel structures, entry barrier columns, interior, etc.

What you need for mounting:

- 2N[®] Helios IP Solo

For not flat surface we recommend to use the module number backplate Part No. 9155068.



⚠ Warning

- 2N[®] Helios IP Solo is not suitable for installation on glass.

⚠ Caution

- The warranty does not apply to the product defects and failures arisen as a result of improper mounting (in contradiction herewith). The manufacturer is neither liable for damage caused by theft within an area that is accessible after the attached electric lock is switched. The product is not designed as a burglar protection device except when used in combination with a standard lock, which has the security function.
- When the proper mounting instructions are not met, water might get in and destroy the electronics. It is because the communicator circuits are under continuous voltage and water infiltration causes an electrochemical reaction. The manufacturer's warranty shall be void for products damaged in this way!
- Do not remove the plastic foil on the inner frame seal to avoid water infiltration and electronic destruction.

General Mounting Principles

✔ **Tip**

- Select flush mounting where possible to make your product elegant looking, more vandal resistant and more secure.
- You are advised to buy the flush mounting boxes in advance and commission your building company to do the masonry for you. This approach helps you put your intercom exactly in the vertical position.

⚠ Caution

- Make sure that the diameter of the dowel holes is accurate to avoid falling out of the dowels! Use the mounting glue to secure the dowels if necessary.
- Make sure that the depth of the dowel holes is accurate!
- Do not use low-quality dowels to avoid their pulling out of the wall!
- Having removed the front panel, make sure that no dirt gets inside the product (especially onto the sealing surface).
- Never turn **2N[®] Helios IP Solo** to align the box assembly after mounting. Make sure that the flush mounting boxes have been installed accurately.
- Check the plasterboard wall and room interior pressure values. If the difference between the values is too great (as a result, e.g., of overpressure ventilation), separate the intercom using, for example, the mounting box enclosed and seal the cable passage to avoid speaker damage.
- Surface mounting may cause problems on places exposed to potential vandalism (such as public garages, etc.). In this case, use steel anchoring elements instead of the dowels and screws included in the delivery.
- The place for surface mounting must be flat with maximum inequality of 0.5 mm. (e.g. desk materials, glass, cutted stone etc). If the place is not flat, use flush mounting, backplate **Part No. 9155068** or equal the wall surface.

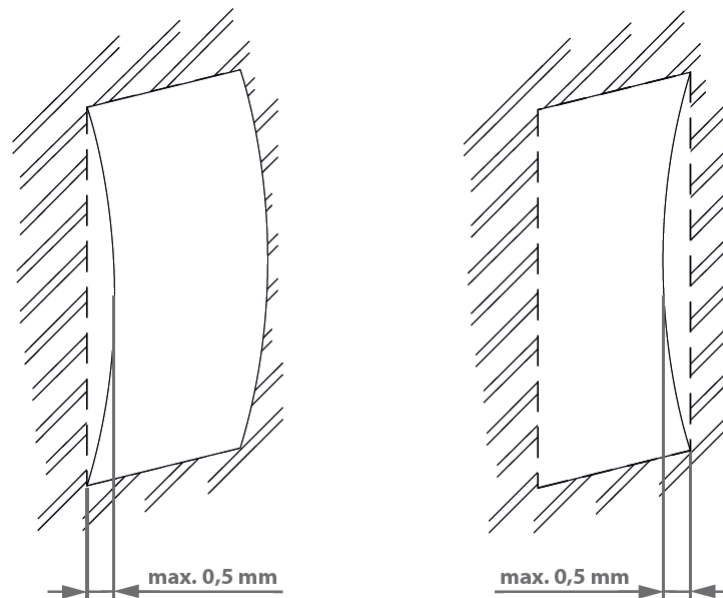

! Safety

- Eliminate the risk of personal injury! Surface mounting is not recommended for narrow passages or places where people's attention is distracted by something else. The manufacturer shall not be liable for injuries in such cases!

Module Installation

- Main Unit Mounting

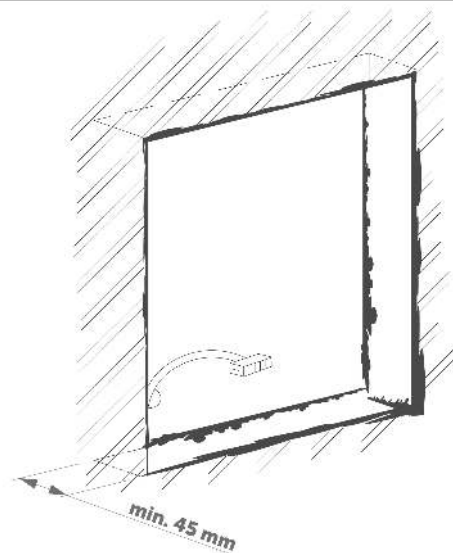
Main Unit Mounting**Flush mounting – classic bricks**

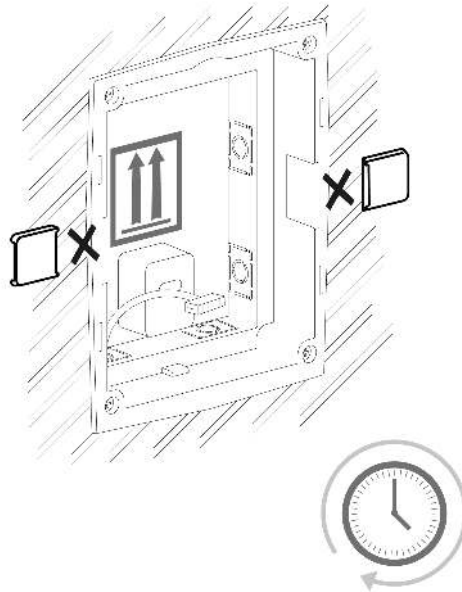
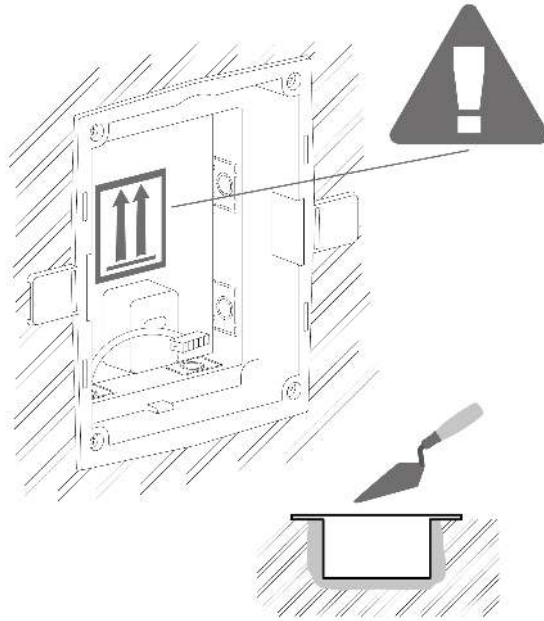

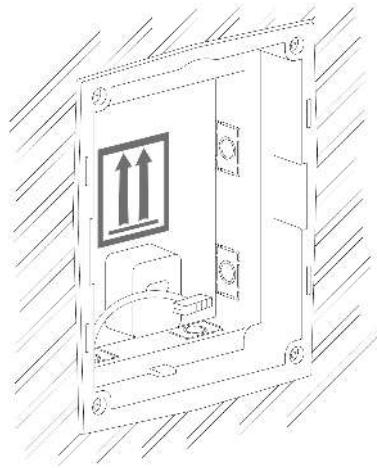

Flush mounting - plasterboard

1x

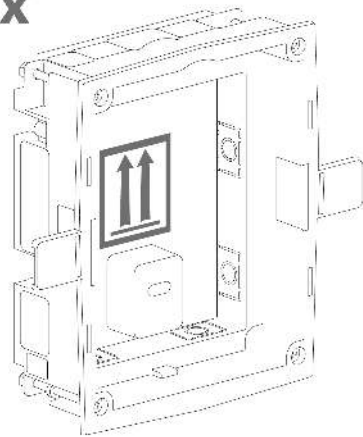

min 108(W) x 136(H)

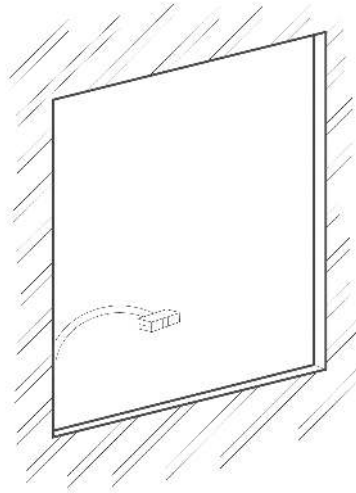
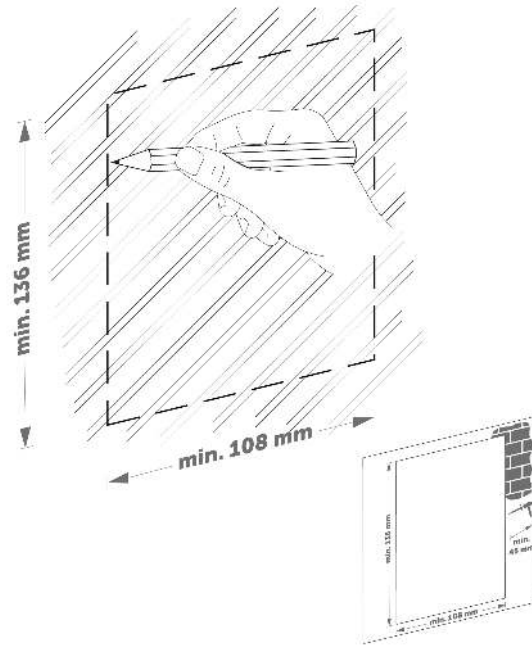

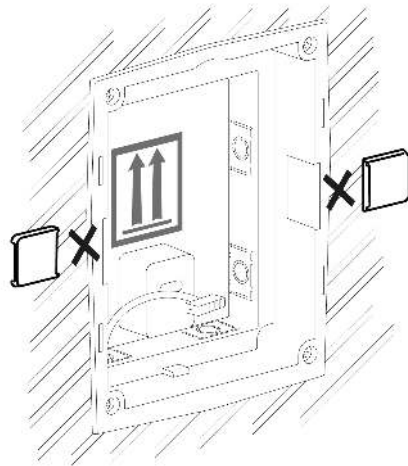
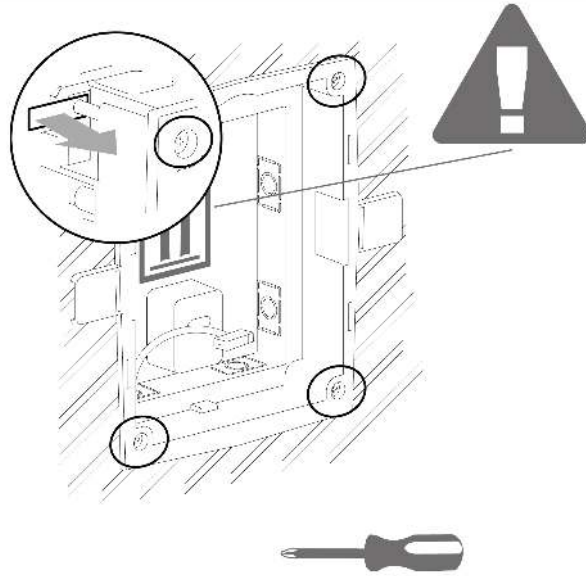

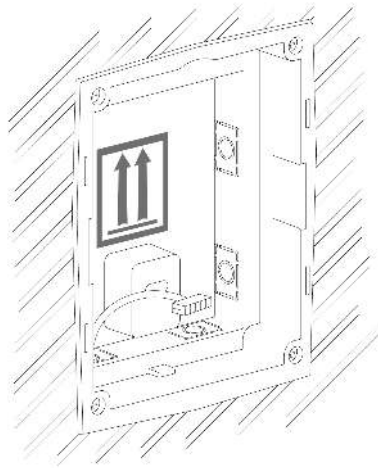

Module flush mounting

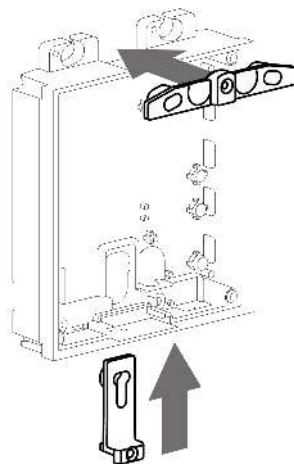
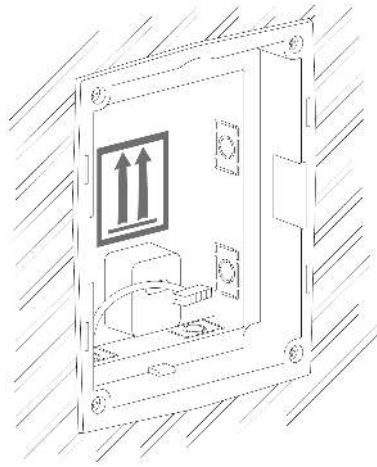

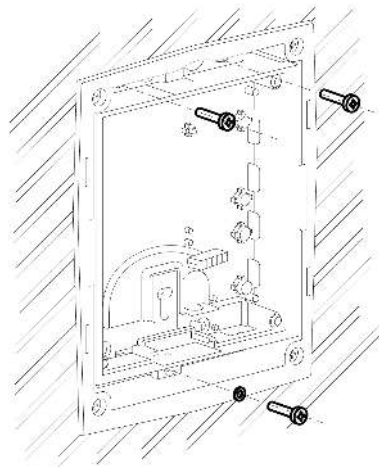
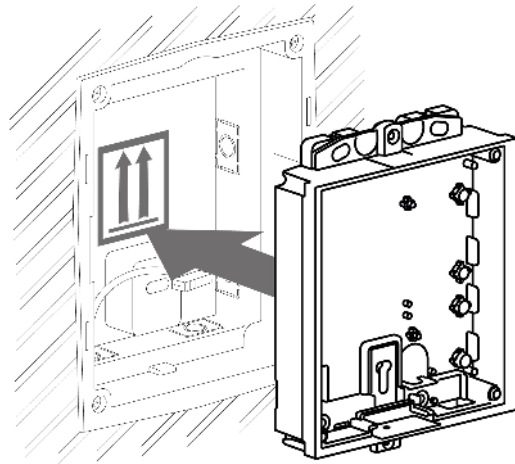

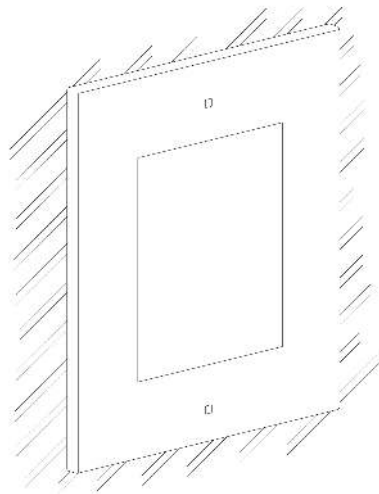
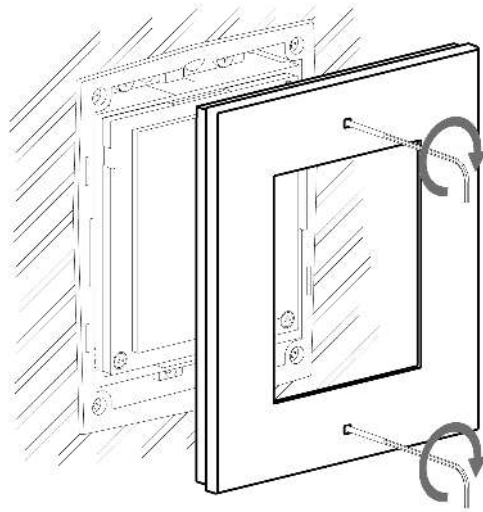

Wall (surface) mounting

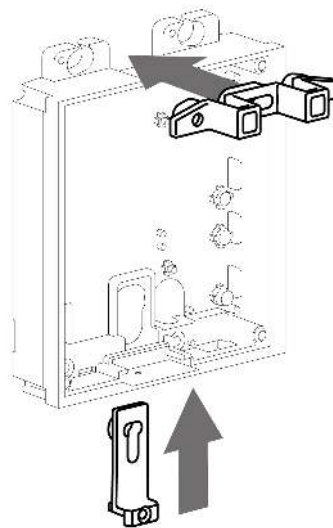
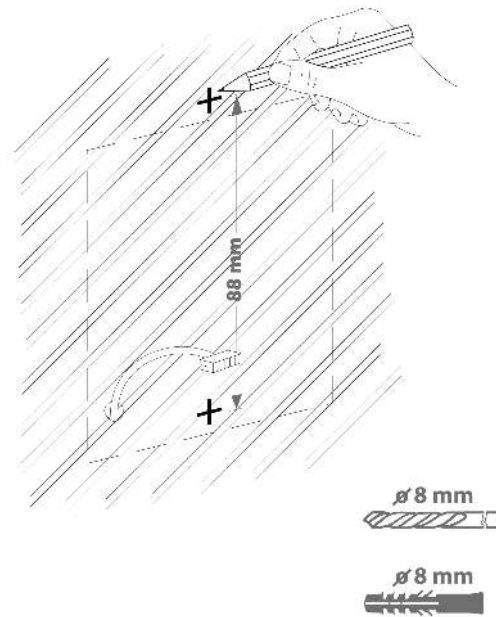

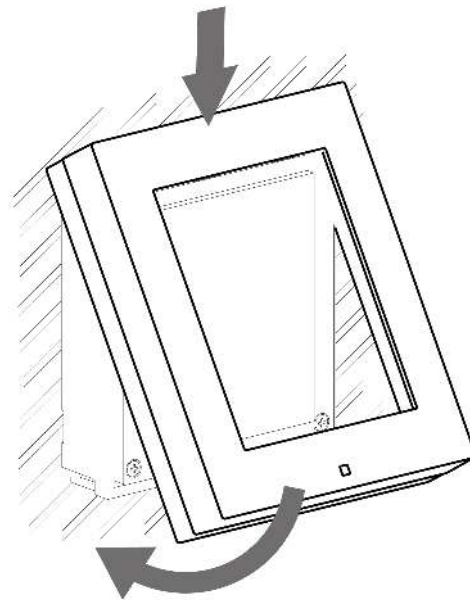
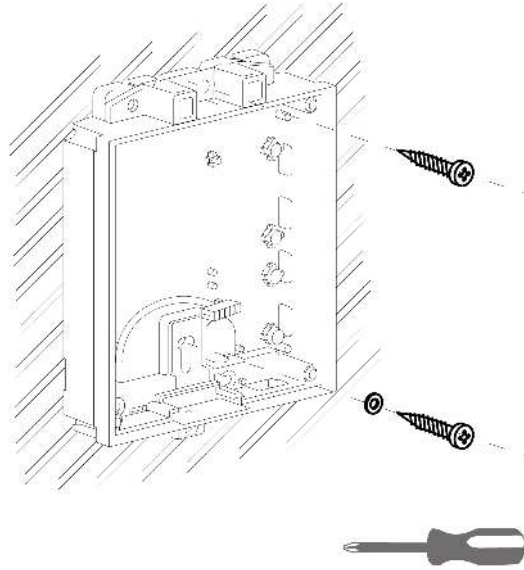

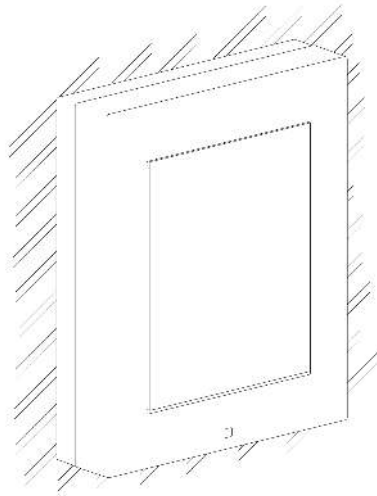
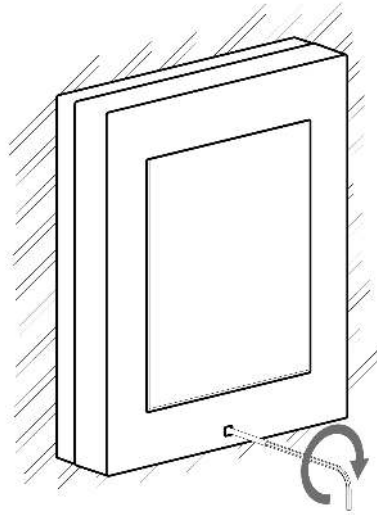

2.3 Electric Installation

This subsection describes how to install the modules, how to connect the 2N[®] Helios IP Solo main unit to the power supply and LAN and how to connect other elements.



Zařízení musí být součástí elektrické instalace budovy.

Mounting Preparation

1. Place the 2N[®] Helios IP Solo on the flush mounting box / pre-drilled holes with dowels and pull the cables through the bottom holes. Pull the Ethernet cable through the bottom hole to the left if necessary.
2. Insert the metal fitting elements up and down and screw the access unit tight. You can level the unit slightly in this mounting type.

Main Unit

Power Supply Connection

2N[®] Helios IP Solo can be powered either from an external 12 V / 2 A DC source or directly from the LAN equipped with PoE 802.3af supporting network elements. Owing to different power outputs, the power supply selection affects the maximum count and applicability of the modules connected of the main unit.

External power supply

Use a 12 V \pm 15 % SELV supply dimensioned to the minimum current consumption of 2 A (Part No. 91341481E) to make your system work reliably. This power supply provides

2N[®] Helios IP Solo with 24 W for feeding of the main unit and connected modules.

PoE Power Supply

2N[®] Helios IP Solo is compatible with the PoE 802.3af (Class 0-12,95 W) technology and can be fed directly from the LAN via the compatible network elements. If your LAN does not support this technology, insert a PoE injector, Part No. 91378100, between 2N[®] Helios IP Solo and the nearest network element. This power supply provides 2N[®] Helios IP Solo with 12 W for feeding of the main unit and connected modules.

Combined Power Supply

2N[®] Helios IP Solo can be fed from an external power supply and PoE at the same time. In this configuration, the maximum power for the connected modules is available.

LAN Connection

2N[®] Helios IP Solo is connected to the Local Area Network (LAN) via the UTP/STP cable (Cat 5e or higher) terminated with an RJ-45 (LAN) connector. As the device is equipped with the Auto-MDIX function, both the straight and crossed cable can be used.

Caution

- We recommend the use of a LAN surge protection.

Main Unit Connector Configuration

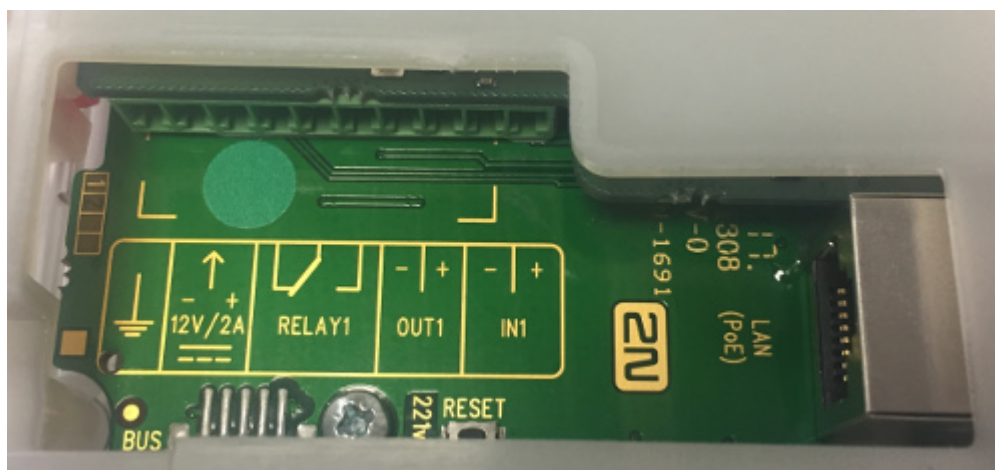

Legend	
LAN (PoE)	LAN (PoE according to 802.1af) connector
IN1	IN1 terminals for input in passive/ active mode (-30 V to +30 V DC) OFF = open OR $U_{IN} > 1.5 \text{ V}$ ON = closed contact OR $U_{IN} < 1.5 \text{ V}$
OUT1	OUT1 terminals of active input for 2N® Helios IP Security Relay or electric lock connection 8 up to 12 V DC depending on power supply (PoE: 10 V; adaptor: power supply voltage minus 2 V), max. 600 mA
RELAY1	RELAY1 terminals with accessible 30 V / 1 A AC/DC NO/NC contact
12V/2A	External 12 V / 2 A DC supply terminals
GND	Grounding terminal
RESET	RESET / FACTORY RESET button

Tip

- Wiring Diagram of IN1 connector in active mode

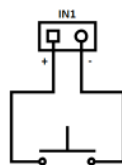

- Wiring Diagram of IN1 connector in passive mode

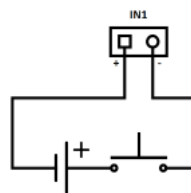

Device Restart

Factory Reset

2N[®] Helios IP Solo is equipped with a RESET button. Press the button shortly (< 1 s) to restart the system without changing configuration.

Follow the instructions below to **identify the current IP address**:

- Press and hold the RESET button.
- Wait until the red and green LEDs on the device come on simultaneously (approx. 20 s).
- Release the RESET button.
- The device announces the current IP address via the loudspeaker connected automatically.



Follow the instructions below to switch on the **Static IP address** mode (DHCP OFF):

- Press and hold the REST button.
- Wait until the red and green LEDs on the device come on simultaneously (approx. 20 s).
- Wait until the red LED goes off (approx. 5 s).
- Release the RESET button.

The following network parameters will be set after restart:

- IP address: 192.168.1.100
- Network mask: 255.255.255.0
- Default gateway: 192.168.1.1



Follow the instructions below to switch on the **Dynamic IP address** mode (DCHP ON):

- Press the RESET button.
- Wait until the red and green LEDs on the device come on simultaneously (approx. 20 s).
- Wait until the red LED goes off (approx. 5 s).
- Wait until the green LED goes off and the red LED comes on again (another 5 s).
- Release the RESET button.

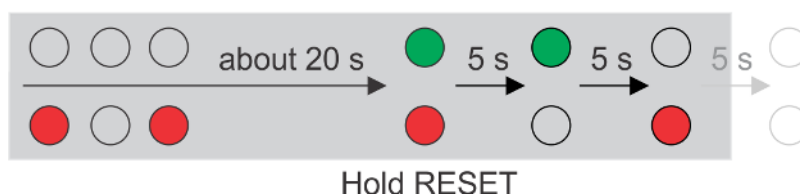

Caution

- In case of resetting the factory default settings on a device with a version of firmware 2.18 or higher it is necessary to reprogram the 2N[®] Helios IP Security Relay using the instructions from section 2.4.

Follow the instructions below to **reset the factory default values**:

- Press the RESET button.
- Wait until the red and green LEDs on the device come on simultaneously (approx. 20 s).
- Wait until the red LED goes off (approx. 5 s).
- Wait until the green LED goes off and the red LED comes on again (approx. 5 s).
- Wait until the red LED goes off (another 5 s).
- Release the RESET button.

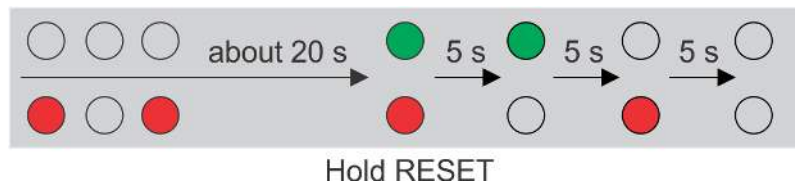

Available Switches

Location	Name	Description
Main Unit	Relay 1	Passive switch: NO/NC contact, up to 30 V / 1 A AC/DC
	Output 1	Active switch output: 8 up to 12 V DC depending on power supply (PoE: 10 V; adaptor: power supply voltage minus 2 V), max. 600 mA

Warning

When you connect a device containing a coil, such as a relay or an electromagnetic lock, it is necessary to protect the intercom against voltage peak while switching off the induction load. For this way of protection we recommend a diode 1 A / 1000 V (e.g., 1N4007, 1N5407, 1N5408) connected antiparallel to the device.

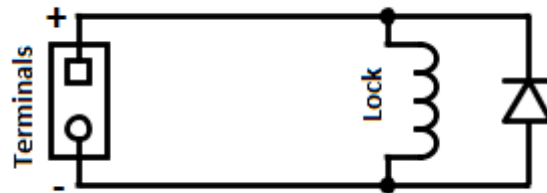

2.4 Extending Module Connection

2N[®] Helios IP Solo allows to connect the following extending modules:

- Security relay

Security Relay

The 2N[®] Helios IP Security Relay (Part No. 9159010) is used for enhancing security between the intercom and the connected electric lock. The 2N[®] Helios IP Security Relay is designed for any 2N Helios IP intercom model with firmware versions 1.15 and higher. It significantly enhances security of the connected electric lock as it prevents lock opening by forced intercom tampering.



Function:

The 2N[®] Helios IP Security Relay is a device installed between an intercom (outside the secured area) and the electric lock (inside the secured area). The 2N[®] Helios IP Security Relay includes a relay that can only be activated if the valid opening code is received from the intercom.

Specifications:

- Passive switch: NO and NC contacts, up to 30 V / 1 A AC/DC
- Active switch output: 12 V / 700 mA DC
- Dimensions: (56 x 31 x 24) mm
- Weight: 20 g

Installation:

Install the 2N[®] Helios IP Security Relay onto a two-wire cable between the intercom and the electric lock inside the area to be secured (typically behind the door). The device is powered and controlled via this two-wire cable and so can be added to an existing installation. Thanks to its compact dimensions, the device can be installed into a standard mounting box.

Connection:

Connect the 2N[®] Helios IP Security Relay to the intercom as follows:

- To the intercom active output (OUT1 or OUT2) , or
- To the intercom relay output with a 12 V DC serial external power supply.

Connect the electric lock to the 2N[®] Helios IP Security Relay output as follows:

- To the active 12 V / 700 mA DC output, or
- To the relay output with a serial external power supply.

The device also supports a Departure button connected between the 'PB' and '- Helios IP' terminals. Press the Departure button to activate the output for 5 seconds.

Status signalling:

Green LED	Red LED	Status
blinking	off	Operational mode
on	off	Activated output
blinking	blinking	Programming mode - waiting for initialisation
on	blinking	Error - wrong code received

Configuration:

- Connect the 2N[®] Helios IP Security Relay to the properly set intercom switch output; refer to the 2N Helios IP Configuration Manual. Make sure that one LED at least on the 2N[®] Helios IP Security Relay is on or blinking.
- Press and hold the 2N[®] Helios IP Security Relay Reset button for 5 seconds to put the device in the programming mode (both the red and green LEDs are blinking).
- Activate the intercom switch using the keypad, telephone, etc. The first code sent from the intercom will be stored in the memory and considered valid. After code initialisation, the 2N[®] Helios IP Security Relay will pass into the operational mode (the green LED is blinking).

Caution

- In case of resetting the factory default settings on a device with a version of firmware 2.18 or higher it is necessary to reprogram the 2N[®] Helios IP Security Relay using the instructions above.

Tip

- FAQ: 2N[®] Helios IP Security Relay - what is it and how to use it with 2N Helios IP intercom?

Tip

- Video Tutorial: Door intercoms 2N[®] Helios IP Security Relay

Connection:

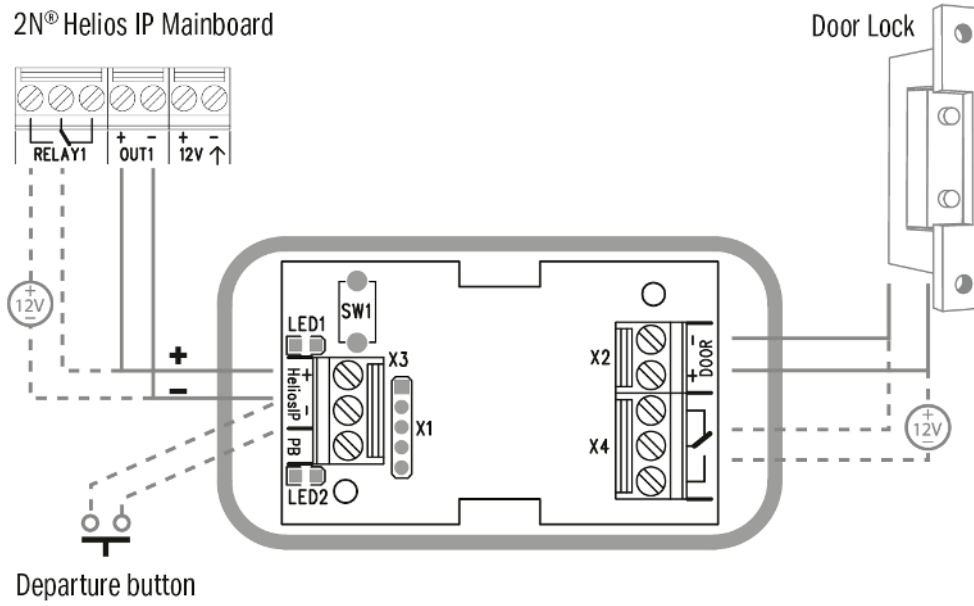

2.5 Completion

Installation Completion

Check the connection of all wires and the RJ-45 plug to the board connector.

 **Caution**

- All unused connectors have to have tightened screws in order to avoid vibration caused by sound.

Nametag Placing

Every intercom package includes a piece of transparent foil, which can be laser printed. Cut the printed foil and insert the nametags in the buttons.

Nametag dimensions for button:

- 1 button: 52.0 (W) x 15.2 (H) mm (dimensional tolerance: +0; -0.5 mm)

 **Caution**

- The area where nametags are placed is called a wet zone. After heavy rain, water can penetrate to the nametag. Water in this area does not affect the intercom functionality in any way and evaporates soon.
- Always use waterproof foil (enclosed or other) for the nametags. Never use paper or ink jet printing to avoid damage due to water leakage!

Nametag inserting/replacing:

1. Remove the frame.
2. Lift up the button door. The 5-button module buttons have just one door.
3. Remove the used nametag and insert a new one.
4. Close the button door.
5. Replace the frame.

Frame Replacement

Check the frame sealing before replacing the frame.

Version A

- Screw the flush mounting frame in the upper and bottom parts.

Version B

- Hang the surface mounting frame on the hook in the upper part and then screw it tight in the bottom part.



Caution

- Improper mounting may deteriorate the intercom waterproofness and water may damage the electronic part.
- Make sure that all holes are filled with some waterproof material - the top part, around the cables and the screws.
- Use silicone or some other sealant to seal the box against the wall if uneven to avoid water leakage and wall damping..

3. Function and Use

This section describes the basic and extending functions of the the 2N[®] Helios IP Solo product.

Here is what you can find in this section:

- **3.1 Configuration**
- **3.2 Intercom Control as Viewed by External User**
- **3.3 Intercom Control as Viewed by Internal User**
- **3.4 Maintenance**
- **3.5 Downloads**

3.1 Configuration

Configure **2N[®] Helios IP Solo** using your PC with any internet browser:

- Launch your internet browser (Internet Explorer, Firefox, etc.).
- Enter the IP address of your intercom (<http://192.168.1.100/>, e.g.).
- Log in using the username **Admin** and password **2n**.

You have to know your intercom IP address to log in to the integrated web server.

Upon purchase, **2N[®] Helios IP Solo** is set to the dynamic IP address mode – it retrieves the IP address automatically if there is a properly configured DHCP server in the LAN.

If no DHCP is available, operate **2N[®] Helios IP Solo** in the static IP address mode. Refer to the **Configuration Manual** for the **2N[®] Helios IP Solo** configuration details.

If your device remains inaccessible (you have forgotten the IP address, the network configuration has changed, etc.), you can change the network configuration using the device buttons.

IP Address Retrieval

Take the following steps to retrieve the **2N[®] Helios IP Solo** IP address:

- Connect (or, if connected, disconnect and reconnect) **2N[®] Helios IP Solo** to the power supply.
- Wait for the second sound signal .
- Press the quick dial button on the main unit 5 times.
- **2N[®] Helios IP Solo** will read its IP address.
- If the address is 0.0.0.0, it means that the intercom has not obtained the IP address from the DHCP server.





i Note

- Be sure to press the button sequence within thirty seconds after the sound signal for security reasons. Up to 2 s intervals are allowed between the presses.

Dynamic/Static IP Address Switching

Take the following steps to switch the dynamic and static IP address mode in 2N[®] Helios IP Solo:

- Connect (or, if connected, disconnect and reconnect) 2N[®] Helios IP Solo to the power supply.
- Wait for the first sound signal .
- Press the quick dial button on the main unit 15 times.
- Switching is signalled with the sound signal .
- Wait until the device is restarted automatically.
- Upon restart, the static IP address mode will be switched to the dynamic IP address mode and vice versa.



The following network parameters will be set after the static IP address mode is switched on and the device is restarted:

- IP address: 192.168.1.100
- Network mask: 255.255.255.0
- Default gateway: 192.168.1.1

Note

- Be sure to press the button sequence within thirty seconds after the sound signal for security reasons. Up to 2 s intervals are allowed between the presses.

3.2 Intercom Control as Viewed by External User

Quick Dial Buttons

Press the quick dial button on the main unit to dial the first position in the phone directory (Phone Book).

By pressing the quick dial buttons you dial the phone numbers assigned to the particular Phone Book position. Call setup is signalled by a long intermittent or any other tone depending on the configuration of the PBX connected.

Repeated pressing of one and the same quick dial button during call setup may initiate call hangup or call termination plus dialling the next phone number of the called subscriber, or may be assigned no function; refer to the Intercom Configuration / Hardware / Keyboard subsection of Configuration Manual.

Calling to Phone Book Position

The 2N[®] Helios IP Solo Phone Book can contain up to 1999 programmable positions.

3.3 Intercom Control as Viewed by Internal User

Call Answering

You can answer the incoming calls to the 2N[®] Helios IP Solo intercom using your phone like any other calls. You can unlock the door, activate/deactivate a user/profile via your phone keypad during the call. The calls, however, are time-limited to avoid unintentional blocking of the 2N[®] Helios IP Solo line. Set the maximum call duration in the **Call time limit** (refer to the Intercom Configuration / Services / Phone / Calls subsection of Configuration Manual). Press # on your phone anytime to extend the call time. The automatic call termination is signalled with a short beep 10 s before the call end.



Calling to 2N[®] Helios IP Solo

2N[®] Helios IP Solo allows you to answer incoming calls. Set the required parameters in the Incoming calls group; refer to the Intercom Configuration / Services / Phone / Calls subsection of Configuration Manual.

Door Opening (Switch Activation) by Code

2N[®] Helios IP Solo is equipped with a door unlocking switch. Enter the valid code (refer to the Intercom Configuration / Hardware / Switches subsection of Configuration Manual) using your phone keypad to activate this switch.

Procedure:

- Enter the switch 1 or 2 activating code using your phone keypad and press  for confirmation. Confirmation is unnecessary if the **Lock code without confirmation** is enabled, refer to the Intercom Configuration / Hardware / Switches / Advanced subsection of Configuration Manual.
- A valid code is signalled by the  sound. An invalid code or interruption longer than as defined in **Timeout for Entering Numbers** is signalled by the  sound.

Cleaning

If used frequently, the device surface, the keypad in particular, gets dirty. To clean it, use a piece of soft cloth moistened with clean water. We recommend you to follow these principles while cleaning:

- Never use aggressive detergents (such as abrasives or strong disinfectants).
- Use suitable cleaning agents for glass lens cleaning (cleaners for glasses, optic devices screens, etc.)
- Clean the device in dry weather in order to make waste water evaporate quickly.

 **Warning**

- Prevent water from getting inside the intercom.
- Do not use alcohol-based cleaners.

3.5 Downloads

Templates

Nameplates

Software

2N® Helios IP eye 1.1.4.0.19

2N® Helios IP network scanner 3.0.4

4. Technical Parameters

Signalling protocol

- SIP (UDP, TCP, TLS)

Buttons

- **Button design:** white-backlit transparent button with replaceable nametags
- **Button count:** 1

Audio

- **Microphone:** 1 integrated microphone
- **Amplifier:** 2 W (class D) amplifier
- **Speaker:** 2 W / 8 Ω
- **Sound pressure level (SPL max):** 71 dB (for 1 kHz, distance 1 m)
- **Output LINE OUT:** 1 VRMS / 600 Ω
- **Volume control:** adjustable with automatic adaptive mode
- **Full duplex:** yes (AEC)
- **Speech transmission index (STI):** 0.89

Audio stream

- **Protocols:** RTP / RTSP
- **Codecs:** G.711, G.729, G.722, L16/16 kHz

Camera

- **Sensor:** 1/3" colour CMOS
- **JPEG resolution:** up to 1280 (H) x 960 (V)
- **Video resolution:** 640 (H) x 480 (V)
- **Frame rate:** up to 30 snapshots/s
- **Sensor sensitivity:** 5.6 V/lux-sec (550 nm)
- **View angle:** 128 ° (H), 95 ° (V), 134 ° (D)
- **Infrared light:** yes

- **Sensor sensitivity without IR light:** 0,1 Lux \pm 20 %
- **Focal length:** 2.25 mm

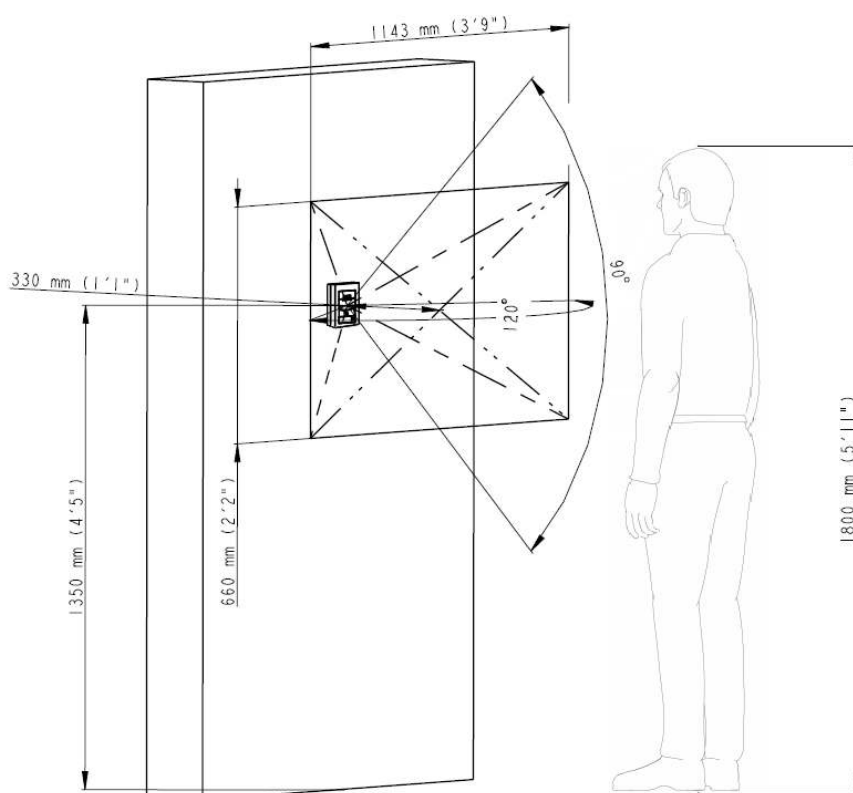

Video stream

- **Protocols:** RTP / RTSP / HTTP
- **Codecs:** H.263, H.263+, H.264, MPEG-4, M-JPEG
- **IP camera function:** yes, ONVIF v2.4 profile S compatible

Interface

- **Power supply:** 12 V \pm 15 % / 2 A DC or PoE
- **PoE:** PoE 802.3af (Class 0-12.95 W)
- **LAN:** 10/100BASE-TX with Auto-MDIX, RJ-45
- **Recommended cabling:** Cat-5e or higher
- **Supported protocols:** SIP2.0, DHCP opt. 66, SMTP, 802.1x, RTSP, RTP, TFTP, HTTP, HTTPS, Syslog, ONVIF
- **Passive switch:** NO/NC contact, up to 30 V / 1 A AC/DC
- **Active switch output:** 8 up to 12 V DC depending on power supply (PoE: 10 V; adaptor: power supply voltage minus 2 V), max. 600 mA

- Tamper switch is part of the 2N[®] Helios IP Solo

Mechanical properties

- **Cover:** robust zinc casting with surface finish (minor surface shade nuances are acceptable)
- **Working temperature:** -40 °C – 60 °C
- **Working relative humidity:** 10 % – 95 % (non-condensing)
- **Storing temperature:** -40 °C – 70 °C
- **Dimensions**
 - **Surface mounting frame:**
 - 107 (W) x 130 (H) x 28 (D) mm
 - 4.21 (W) x 5.12 (H) x 1.10 (D) inches
 - **Flush mounting frame:**
 - 130 (W) x 153 (H) x 5 (D) mm
 - 5.12 (W) x 6.02 (H) x 0.20 (D) inches
 - **Flush mounting box (minimum hole dimensions):**
 - 108 (W) x 131 (H) x 45 (D) mm
 - 4.25 (W) x 5.16 (H) x 1.77 (D) inches
- **Weight:** max net weight: 1 kg
- **Covering level:** IP54
- **Resistance level:** IK08

5. Supplementary Information

Here is what you can find in this section:

- 5.1 Troubleshooting
- 5.2 Directives, Laws and Regulations
- 5.3 General Instructions and Cautions

5.1 Troubleshooting



For the most frequently asked questions refer to faq.2n.cz.

5.2 Directives, Laws and Regulations

Europe

2N[®] Helios IP Solo conforms to the following directives and regulations:

Directive 1999/5/EC of the European Parliament and of the Council, of 9 March 1999 - on radio equipment and telecommunications terminal equipment and the mutual recognition of their conformity

Directive 2006/95/EC of the European Parliament and of the Council of 12 December 2006 on the harmonisation of the laws of Member States relating to electrical equipment designed for use within certain voltage limits

Directive 2004/108/EC of the Council of 15 December 2004 on the harmonisation of the laws of Member States relating to electromagnetic compatibility

Commission Regulation (EC) No. 1275/2008, of 17 December 2008, implementing Directive 2005/32/EC of the European Parliament and of the Council with regard to ecodesign requirements for standby and off mode electric power consumption of electrical and electronic household and office equipment

Directive 2011/65/EU of the European Parliament and of the Council of 8 June 2011 on the restriction of the use of certain hazardous substances in electrical and electronic equipment

Regulation (EC) No. 1907/2006 of the European Parliament and of the Council of 18 December 2006 concerning the Registration, Evaluation, Authorisation and Restriction of Chemicals (REACH), establishing a European Chemicals Agency, amending Directive 1999/45/EC and repealing Council Regulation (EEC) No. 793/93 and Commission Regulation (EC) No. 1488/94 as well as Council Directive 76/769/EEC and Commission Directives 91/155/EEC, 93/67/EEC, 93/105/EC and 2000/21/EC

Directive 2012/19/EC of the European Parliament and of the Council of 4 July 2012 on waste electrical and electronic equipment.

Industry Canada

This Class B digital apparatus complies with Canadian ICES-003. / Cet appareil numérique de la classe B est conforme à la norme NMB-003 du Canada.

FCC

NOTE: This equipment has been tested and found to comply with the limits for a Class B digital device, pursuant to part 15 of the FCC Rules. These limits are designed to provide reasonable protection against harmful interference in a residential installation.

This equipment generates, uses and can radiate radio frequency energy and, if not installed and used in accordance with the instructions, may cause harmful interference to radio communications. However, there is no guarantee that interference will not occur in a particular installation. If this equipment does cause harmful interference to radio or television reception, which can be determined by turning the equipment off and on, the user is encouraged to try to correct the interference by one or more of the following measures:

- Reorient or relocate the receiving antenna
- Increase the separation between the equipment and receiver
- Connect the equipment into an outlet on a circuit different from that to which the receiver is connected
- Consult the dealer or an experienced radio/TV technician for help.

Changes or modifications to this unit not expressly approved by the party responsible for compliance could void the user's authority to operate this equipment.

5.3 General Instructions and Cautions

Please read this User Manual carefully before using the product. Follow all instructions and recommendations included herein.

Any use of the product that is in contradiction with the instructions provided herein may result in malfunction, damage or destruction of the product.

The manufacturer shall not be liable and responsible for any damage incurred as a result of a use of the product other than that included herein, namely undue application and disobedience of the recommendations and warnings in contradiction herewith.

Any use or connection of the product other than those included herein shall be considered undue and the manufacturer shall not be liable for any consequences arisen as a result of such misconduct.

Moreover, the manufacturer shall not be liable for any damage or destruction of the product incurred as a result of misplacement, incompetent installation and/or undue operation and use of the product in contradiction herewith.

The manufacturer assumes no responsibility for any malfunction, damage or destruction of the product caused by incompetent replacement of parts or due to the use of reproduction parts or components.

The manufacturer shall not be liable and responsible for any loss or damage incurred as a result of a natural disaster or any other unfavourable natural condition.

The manufacturer shall not be held liable for any damage of the product arising during the shipping thereof.

The manufacturer shall not make any warrant with regard to data loss or damage.

The manufacturer shall not be liable and responsible for any direct or indirect damage incurred as a result of a use of the product in contradiction herewith or a failure of the product due to a use in contradiction herewith.

All applicable legal regulations concerning the product installation and use as well as provisions of technical standards on electric installations have to be obeyed. The manufacturer shall not be liable and responsible for damage or destruction of the product or damage incurred by the consumer in case the product is used and handled contrary to the said regulations and provisions.

The consumer shall, at its own expense, obtain software protection of the product. The manufacturer shall not be held liable and responsible for any damage incurred as a result of the use of deficient or substandard security software.

The consumer shall, without delay, change the access password for the product after installation. The manufacturer shall not be held liable or responsible for any damage incurred by the consumer in connection with the use of the original password.

The manufacturer also assumes no responsibility for additional costs incurred by the consumer as a result of making calls using a line with an increased tariff.

Electric Waste and Used Battery Pack Handling



Do not place used electric devices and battery packs into municipal waste containers. An undue disposal thereof might impair the environment!

Deliver your expired electric appliances and battery packs removed from them to dedicated dumpsites or containers or give them back to the dealer or manufacturer for environmental-friendly disposal. The dealer or manufacturer shall take the product back free of charge and without requiring another purchase. Make sure that the devices to be disposed of are complete.

Do not throw battery packs into fire. Battery packs may not be taken into parts or short-circuited either.

